

## mTray Accessory Rail

### USER MANUAL

mTray Accessory Rail  
LX model - Length 36"

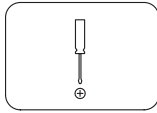

#### Components

Self Tapping Phillips Screw (6)

Phillips Washer Head Self Tapping Screw (2)



Cable Lead (1)



Cable Holder Single model (2)

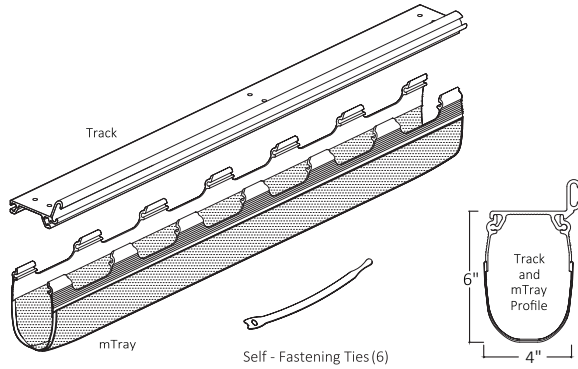

#### STEP 1: Attach track to underside of work surface.

- With all monitors and accessories in place, decide where to attach the track on the rear underside of the work surface.

**IMPORTANT:** make sure to leave extra space between the wall surface or vertical panel and end of the desk for wires and cables.

- Use minimum 2" wide painter's tape to hold the Track in the desired position.

- Using the track holes as a template, mark, and drill 3/32" pilot holes about 1/8" deep.

**CAUTION:** Be careful not to drill through the top of the work surface.

- Attach the track with the Self Tapping Phillips Screws. Track must be secured firmly. Then remove the painter's tape.

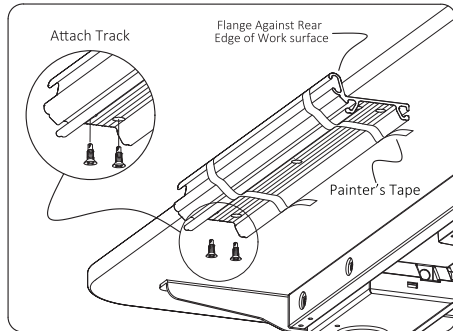

#### STEP 2: Attach mTray to one side of the track.

(See illustration above right.)

- Insert the top of the mesh tray into one side of the track and then snap down into place.

- Insert the Self-Fastening Ties under the fabric strips in the tray. Place them where the power components will be located.

- Static load capacity is 20 lbs (9.1 kilograms) when product is secured with specified screws

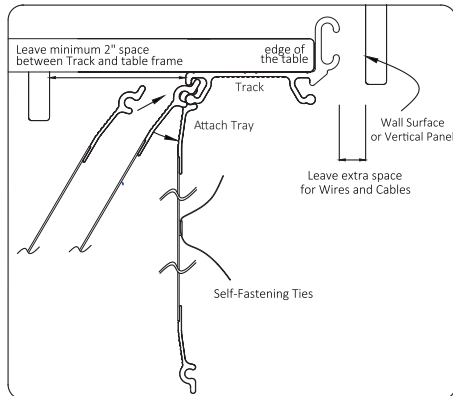

**WARNING:** To be installed on Desk Tops with a minimum thickness of 3/4"

**NOTE:** For any other installation of "cTray" or "mTray" product to a desk surface, SFI Office cannot specify load capacity when conditions will depend on the specific surface, adhesive type, or type of fastener.

## mTray Accessory Rail

### USER MANUAL

mTray Accessory Rail  
LX model - Length 36"

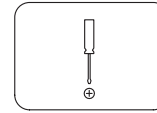

#### Components

Self Tapping Phillips Screw (6)

Phillips Washer Head Self Tapping Screw (2)



Cable Lead (1)



Cable Holder Single model (2)

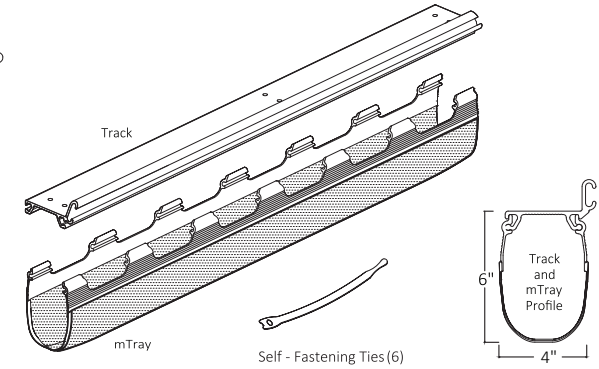

#### STEP 1: Attach track to underside of work surface.

- With all monitors and accessories in place, decide where to attach the track on the rear underside of the work surface.

**IMPORTANT:** make sure to leave extra space between the wall surface or vertical panel and end of the desk for wires and cables.

- Use minimum 2" wide painter's tape to hold the Track in the desired position.

- Using the track holes as a template, mark, and drill 3/32" pilot holes about 1/8" deep.

**CAUTION:** Be careful not to drill through the top of the work surface.

- Attach the track with the Self Tapping Phillips Screws. Track must be secured firmly. Then remove the painter's tape.

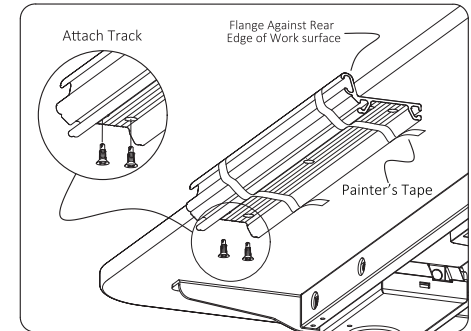

#### STEP 2: Attach mTray to one side of the track.

(See illustration above right.)

- Insert the top of the mesh tray into one side of the track and then snap down into place.

- Insert the Self-Fastening Ties under the fabric strips in the tray. Place them where the power components will be located.

- Static load capacity is 20 lbs (9.1 kilograms) when product is secured with specified screws

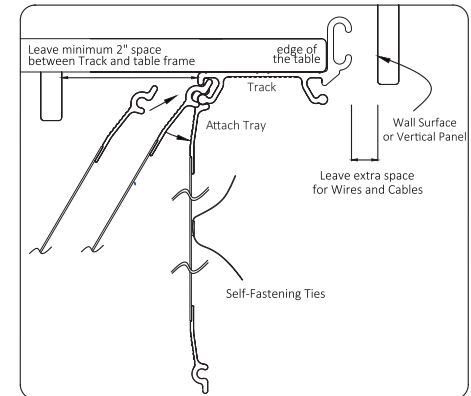

**WARNING:** To be installed on Desk Tops with a minimum thickness of 3/4"

**NOTE:** For any other installation of "cTray" or "mTray" product to a desk surface, SFI Office cannot specify load capacity when conditions will depend on the specific surface, adhesive type, or type of fastener.

**STEP 3:** Insert Cable Holder onto track flange.

- Fit the Cable Holder into the channels on the flange.
- Position the Holder where they can route cables into the mTray.

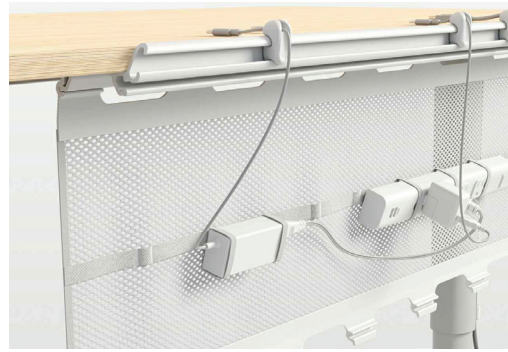
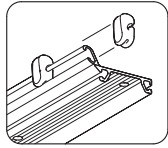

**STEP 4:** Attach electrical components to tray.

- Use the Self-Fastening Ties to secure the components.
- In addition to the cables, the mTray can accommodate transformers, power strips, USB hubs, and other electrical accessories.
- Notice how the cable clips are used to neatly route the cables.

**STEP 5:** Finish tray installation.

- Snap the loose side of the tray into the other edge of the track (see STEP 2).
- If desired, capture cords in the openings at the top of the Tray.

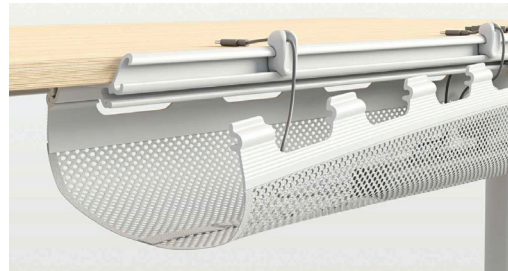

**STEP 6:** Attach Cable Lead.

- Once all cables and accessories are in the tray, decide where to place Cable Leads. Typically, they are placed near the leg where the cables are routed down toward the outlet.

Using the Cable Lead as a template and with a pick tool, make a deep mark for two holes on the underside of the work surface.

- Attach the Cable Lead to the underside of the work surface using the two Philips-Washer Head Self Tapping Screws. You can snap the Cables into the ends of the Cable Lead and its center.

NOTE: You can use multiple Cable Leads to route cables from various equipment and bring them to central location near the Table leg and Cable Conduit to safely route the cables to the wall or floor Power and Data outlets.

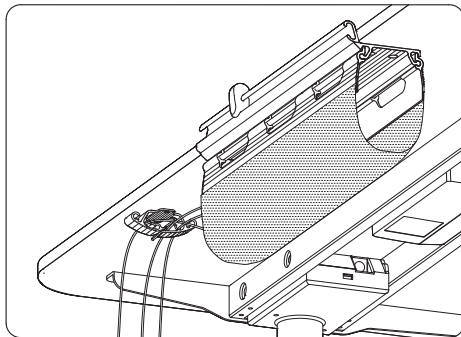
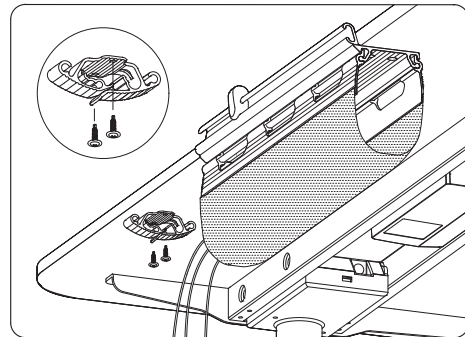
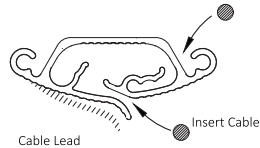

**WARNING:** To be installed on Desk Tops with a minimum thickness of 3/4"

**STEP 3:** Insert Cable Holder onto track flange.

- Fit the Cable Holder into the channels on the flange.
- Position the Holder where they can route cables into the mTray.

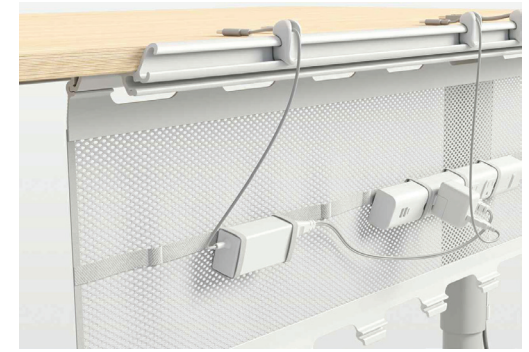
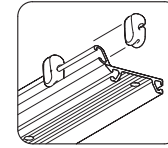

**STEP 4:** Attach electrical components to tray.

- Use the Self-Fastening Ties to secure the components.
- In addition to the cables, the mTray can accommodate transformers, power strips, USB hubs, and other electrical accessories.
- Notice how the cable clips are used to neatly route the cables.

**STEP 5:** Finish tray installation.

- Snap the loose side of the tray into the other edge of the track (see STEP 2).
- If desired, capture cords in the openings at the top of the Tray.

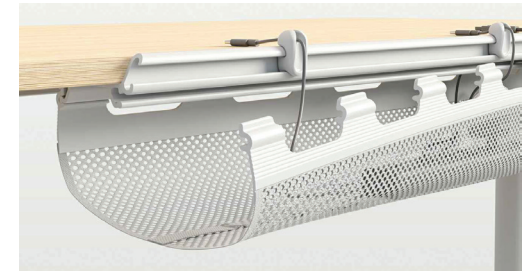

**STEP 6:** Attach Cable Lead.

- Once all cables and accessories are in the tray, decide where to place Cable Leads. Typically, they are placed near the leg where the cables are routed down toward the outlet.

Using the Cable Lead as a template and with a pick tool, make a deep mark for two holes on the underside of the work surface.

- Attach the Cable Lead to the underside of the work surface using the two Philips-Washer Head Self Tapping Screws. You can snap the Cables into the ends of the Cable Lead and its center.

NOTE: You can use multiple Cable Leads to route cables from various equipment and bring them to central location near the Table leg and Cable Conduit to safely route the cables to the wall or floor Power and Data outlets.

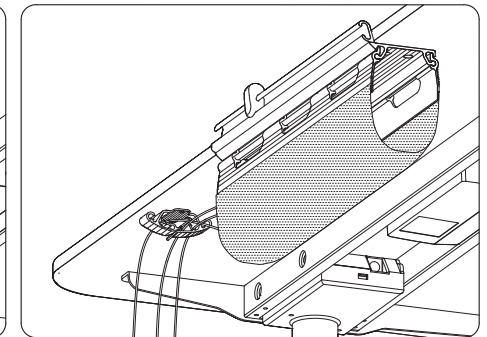
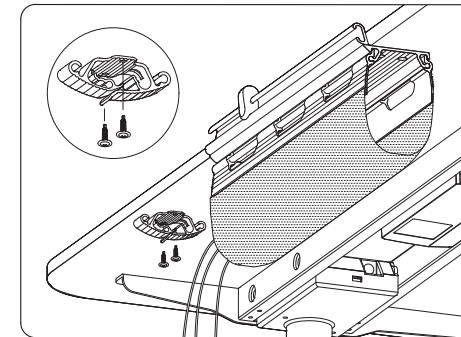
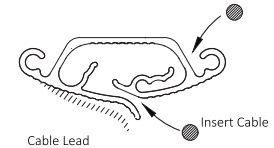

**WARNING:** To be installed on Desk Tops with a minimum thickness of 3/4"

Visit our website for discovering additional products, maintenance, warranty information, and to find the latest news from SFI Office:  
[www.sfioffice.com](http://www.sfioffice.com)

Visit our website for discovering additional products, maintenance, warranty information, and to find the latest news from SFI Office:  
[www.sfioffice.com](http://www.sfioffice.com)