

cTray

USER MANUAL

cTray L model - Length 17½"

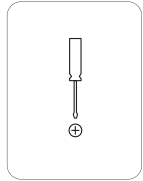

Components

Phillips Washer Head Self Tapping Screw (6)



Cable Lead (1)



Cable Holder - Single model (2)

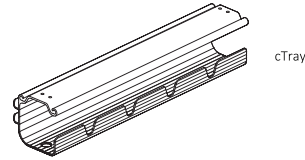

cTray

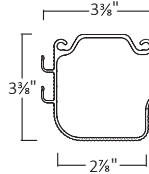

STEP 1: Attach cTray to underside of work surface.

- With all monitors and accessories in place, decide where to attach the tray on the rear underside of the work surface. **IMPORTANT:** leave extra space between the wall surface or vertical panel and the end of the desk for wire and cables.
- Use 2" wide painter's tape to hold the cTray in the desired position.
- Use the cTray as the template, mark and drill 1/16" pilot holes about ½" deep. **CAUTION:** Be careful not to drill through the top of the work surface.
- Attach the tray with the Phillips Washer Head Self Tapping Screws. cTray must be secured safely. Then remove the painter's tape.
- Static load capacity is 9 lbs. (4.1 kilograms) when product is secured with specified screws.

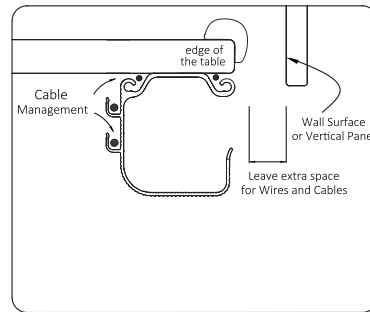

WARNING: To be installed on Desk Tops with a minimum thickness of 3/4"

NOTE: For any other installation of "cTray" or "mTray" product to a desk surface, SFI Office cannot specify load capacity when conditions will depend on the specific surface, adhesive type, or type of fastener.

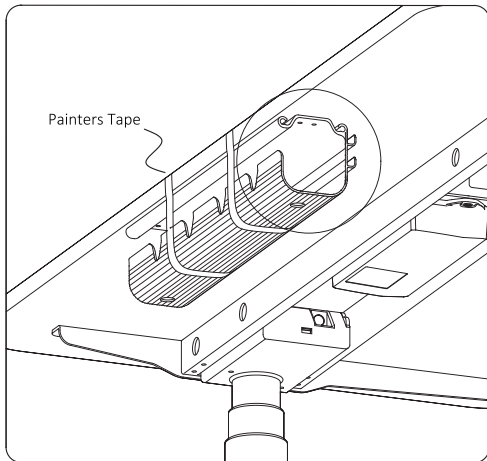
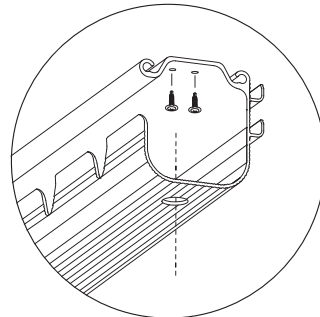

cTray

USER MANUAL

cTray L model - Length 17½"

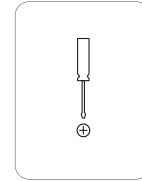

Components

Phillips Washer Head Self Tapping Screw (6)



Cable Lead (1)



Cable Holder - Single model (2)

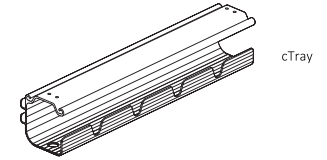

cTray

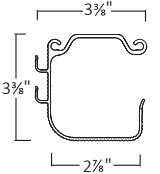

STEP 1: Attach cTray to underside of work surface.

- With all monitors and accessories in place, decide where to attach the tray on the rear underside of the work surface. **IMPORTANT:** leave extra space between the wall surface or vertical panel and the end of the desk for wire and cables.
- Use 2" wide painter's tape to hold the cTray in the desired position.
- Use the cTray as the template, mark and drill 1/16" pilot holes about ½" deep. **CAUTION:** Be careful not to drill through the top of the work surface.
- Attach the tray with the Phillips Washer Head Self Tapping Screws. cTray must be secured safely. Then remove the painter's tape.
- Static load capacity is 9 lbs. (4.1 kilograms) when product is secured with specified screws.

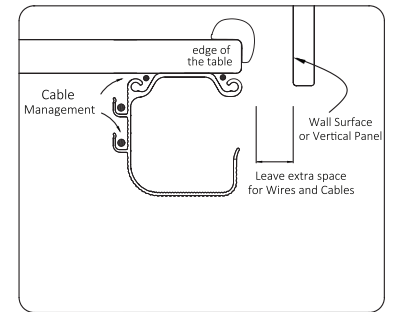

WARNING: To be installed on Desk Tops with a minimum thickness of 3/4"

NOTE: For any other installation of "cTray" or "mTray" product to a desk surface, SFI Office cannot specify load capacity when conditions will depend on the specific surface, adhesive type, or type of fastener.

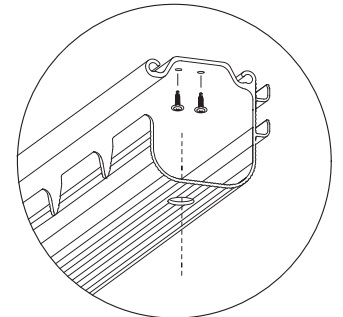
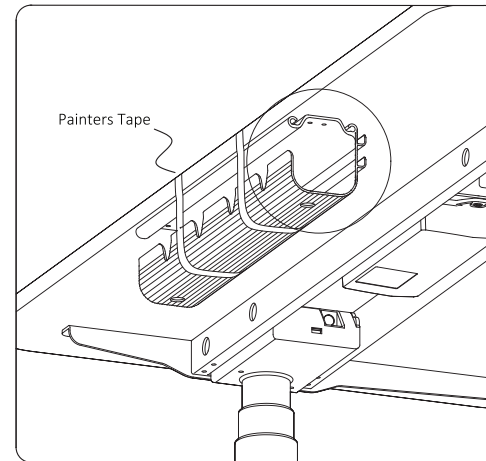

STEP 2: Place Cable Holder on the work surface edge

- Place the Cable Holder in the desired position along the work surface edge where it can route cables into the cTray.

STEP 3: Place electrical components in the tray.

- In addition to the cables, the CTray can accommodate transformers, power strips, USB hubs, and other electrical accessories. Notice how the Cable Holders are used to route the cables neatly.

STEP 4: Attach Cable Lead.

- Once all cables and accessories are in the tray, decide where to place the Cable Lead. Typically, it is placed near the leg where the cables are routed down toward the outlet.

- Using the Cable Lead as a template, and with pick tool, make a deep mark for two holes on the underside of the work surface.

- Attach each Cable Lead to the underside of the work surface using the two Philips Washer Head Self Tapping Screws.

- Cables can be snapped into the ends of the Cable Lead and into its center.

NOTE: You can use multiple Cable Leads to route cables from various equipment and bring them to central location near the Table leg and Cable Conduit to safely route the cables to the wall or floor Power and Data outlets.

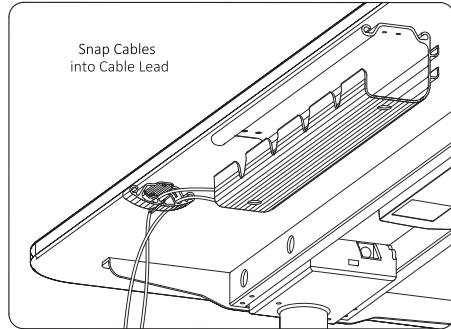
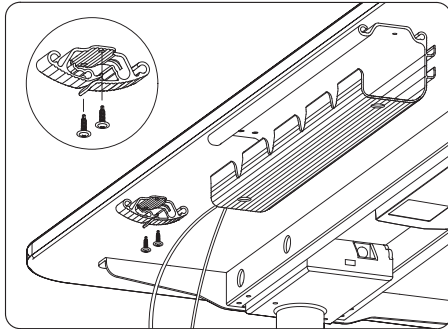
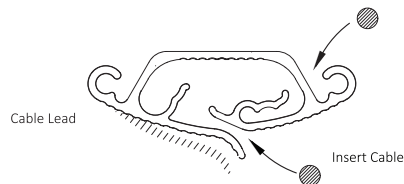

WARNING: To be installed on Desk Tops with a minimum thickness of 3/4"

STEP 2: Place Cable Holder on the work surface edge

- Place the Cable Holder in the desired position along the work surface edge where it can route cables into the cTray.

STEP 3: Place electrical components in the tray.

- In addition to the cables, the CTray can accommodate transformers, power strips, USB hubs, and other electrical accessories. Notice how the Cable Holders are used to route the cables neatly.

STEP 4: Attach Cable Lead.

- Once all cables and accessories are in the tray, decide where to place the Cable Lead. Typically, it is placed near the leg where the cables are routed down toward the outlet.

- Using the Cable Lead as a template, and with pick tool, make a deep mark for two holes on the underside of the work surface.

- Attach each Cable Lead to the underside of the work surface using the two Philips Washer Head Self Tapping Screws.

- Cables can be snapped into the ends of the Cable Lead and into its center.

NOTE: You can use multiple Cable Leads to route cables from various equipment and bring them to central location near the Table leg and Cable Conduit to safely route the cables to the wall or floor Power and Data outlets.

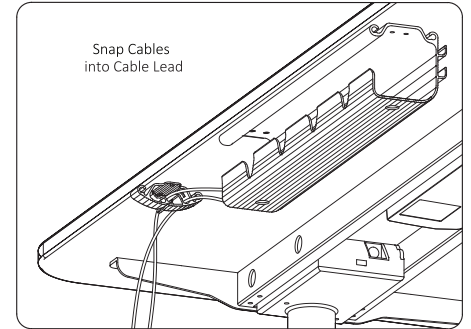
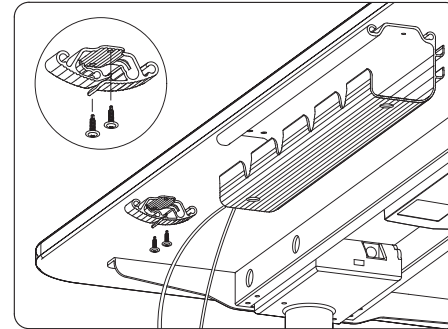
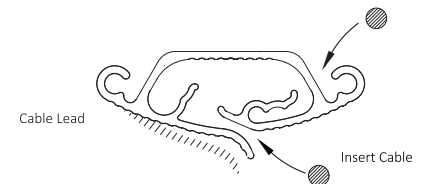

WARNING: To be installed on Desk Tops with a minimum thickness of 3/4"